

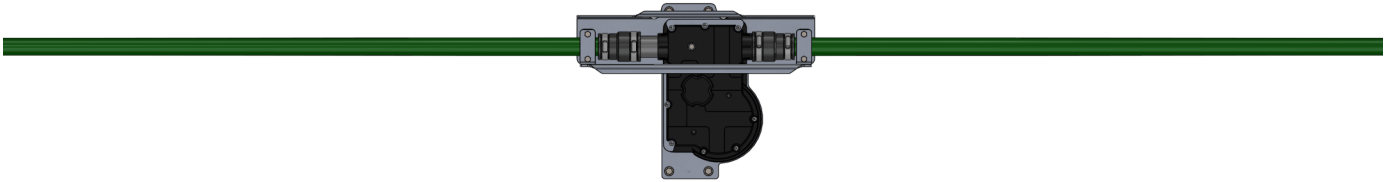

Dipole Instruction Manual



ANTENNA SPECIFICATIONS

Dipole Specifications

Specifications	Dipole
Boom length	N/A
Boom outside diameter	N/A
Longest element	36 ft / 10.97 m
Turning radius	18 ft / 5.48 m
Weight	15 lb / 6.8 kg
*Projected area	3.46 sq ft / 0.32 sq m
Mast Hardware	1.75 in / 4.45 cm
Wind rating	100 mph
Adjustable elements	1
Power Rating	3000 watts continuous
Feed points	1
Frequency coverage	13.85 MHz—54 MHz
Control cable	4 conductor shielded, 22AWG

*Projected area is the total perpendicular surface area measured in square feet/square meters, that is exposed to wind. To calculate wind load you always take the largest projected area whether that is from the perspective perpendicular to the boom or perpendicular to the elements. In the case of SteppIR Yagi's, the maximum projected area will always be the sum of the surface area's perpendicular to the Yagi elements. This calculation is a constant number and will not change regardless of EIA specification changes. Do not mistake this projected area calculation as anything more than a datapoint to present to your structural engineer, tower manufacturer or rotator manufacturer so that they can determine what is necessary for your application.

When sizing an antenna to a tower, many factors need to be taken into consideration including, but not limited to: projected area of antenna in square feet or square meters, weight of the antenna and other items on tower, turning radius, element lengths, antenna height, location exposure category, locations three-second gust wind-speed, locations maximum radial ice loading.

Improper specification of an antenna or rotator to a tower can result in product failure, injury or death. SteppIR is not an expert on tower or rotator sizing and for this reason will never offer any recommendation – this specification process is meant for industry professionals such as a structural engineer, tower manufacturer or rotator manufacturer. Please do not attempt to self-specify our products – the information provided by SteppIR is to be utilized by industry professionals only and we will not accept any liability for improperly specified antenna/tower/rotator applications.

TABLE OF CONTENTS

SteppIR - Why Compromise?	4
Preamble by Jim Streible	5-6
SteppIR Design	7
Abbreviations	8
Parts Checklist	9-10
Stainless Steel Fastener Information	11
Antenna Direction Configuration	12
Antenna Overview and Diagram	13
Section 1: Control Cable, and EHU Wiring	14-18
Section 2: EHU Wiring Tests	19-20
Section 3: Attaching the EHU to the DB Mounting Plate	21
Section 4: Telescoping Poles and Foam Plug Assemblies	22-23
Section 5: Attaching Elements to the EHU, and Installing Mast Clamps	24-26
PTT Lockout Tuning Relay (Included)	27
1:1 Balun (Optional)	28
Voltage/Surge Suppressor (Optional)	29
Grounding the Controller (Mandatory)	30
How to Tune Your Dipole (Mandatory)	31-33
SteppIR Options	34
Product Warranty Claim	35

STEPPIR — WHY COMPROMISE?

The SteppIR antenna was originally conceived to solve the problem of covering the six ham bands (20m, 17m, 15m, 12m, 10m and 6m) on one tower without the performance sacrifices caused by interaction between all of the required antennas.

Yagi's are available that cover 20 meters through 10 meters by using interlaced elements or traps, but do so at the expense of significant performance reduction in gain and front to back ratios. With the addition of the WARC bands on 17m and 12m, the use of interlaced elements and traps has clearly been an exercise in diminishing returns.

Obviously, an antenna that is precisely adjustable in length while in the air would solve the frequency problem, and in addition would have vastly improved performance over existing fixed length yagi's. The ability to tune the antenna to a specific frequency, without regard for bandwidth, results in excellent gain and front to back at every frequency.

The SteppIR design was made possible by the convergence of determination and high tech materials. The availability of new lightweight glass fiber composites, Teflon blended thermoplastics, high conductivity copper-beryllium and extremely reliable stepper motors has allowed the SteppIR to be a commercially feasible product.

The current and future SteppIR products should produce the most potent single tower antenna systems ever seen in Amateur Radio! We thank you for using our SteppIR antenna for your ham radio endeavors.

Warm Regards,

John Mertel

*John Mertel - WA7IR
President/CEO*



PREAMBLE

OK - - - NOW WHAT? (Sage advice from Jim Streible, K4DLI, SK)

You have ordered your SteppIR Antenna and are waiting for delivery. What do you do in the meantime?

1. Go to the SteppIR web site at www.consumer.steppir.com and download the latest manual for your antenna, and also the Operators Manual for the controller.
2. Read the manuals from cover-to-cover ---TWICE! Don't just read them --Study them, so you are familiar the terminology used about the antennas and have a good idea of how the antenna is assembled and where the various parts go.
3. As you go through the manuals make notes of any instructions you may not clearly understand, then call or email for clarifications. It is better to have it all sorted out before you start assembly. We don't mind answering your questions beforehand.
4. Now, wait for notification your antenna is being shipped.

Your antenna has arrived! What is the first thing to do?

1. If the antenna is to arrive on Wednesday----DO NOT plan an antenna party for Saturday!
2. Even if you plan to install the antenna weeks later, the first thing to do is to unpack the antenna and do a complete inspection. Make sure nothing is missing or has been damaged in shipment.
3. Do a complete inventory of every part, nut and bolt. Yes it takes time, but it also allows you to notify SteppIR if anything is missing and allow time to get it to you before you start assembly of the antenna. There is nothing more frustrating than realizing that something is missing, just hours before you want to install the antenna.
4. Go back to the SteppIR website and download the latest manual. SteppIR constantly is improving and adding to the manual, so even though your version of the instruction manual is going to have all the data you need, it makes sense to check for the latest updates online. This is especially true if you purchased the antenna and a period of time has passed between arrival and installation dates.
5. Take the controller and power supply out of their wrappings and connect them. The controller does not have to be connected to the antenna in order to familiarize yourself with it. In fact, it is best to get familiar with the controller when it is not connected to the antenna. Turn on the controller and read through the Operators Manual again while operating the controller in all its modes. Go through the menus so you know what each does and how to navigate through the various menus and functions.
6. When you are familiarizing yourself with the controller be sure to verify that the controller is set for your antenna type, or your antenna will not work properly on 40m and 30m, if it's capable. If you are installing the 6m passive element, be sure to enable that as well.

PREAMBLE

OK - - - NOW WHAT?
(Sage advice from Jim Streible, K4DLI, SK)

Your Antenna Has Arrived!
What is the first thing to do?
(continued)

7. When you have finished working with the controller be sure the display indicates “Elements Home” and the controller has been turned OFF. When the controller is connected to the antenna and the controller is turned back on the next time, it will think the antenna is in whatever position the controller was left in last time you were using it, so you want to be sure that position is HOME.
8. Once the antenna is completely assembled and ready to mount on the antenna tower, use an antenna analyzer, if you have one, to test resonance of the antenna. If you don't have an analyzer, try to borrow one or purchase one, they are inexpensive and readily available (The NanoVNA is a great example). It will save you a lot of time and worry. Check the antenna on each band for some sign of resonance within the frequency range. Leave the antenna on the default frequency and scan the ham band (you may need to open up the span to be outside of the band) with the analyzer to see where the dip occurs. It will be somewhere below the lower band edge on each band with the antenna 3 or 4 feet above the ground on sawhorses. Also, don't expect to see a 1:1 SWR here (on lower frequencies you may see up to a 2.5 or 3:1), just look for a good indication of resonance.

Once it has been determined this part of the antenna is working correctly do the following: Select the lowest band and establish the dip condition by tuning the analyzer. Do not touch the analyzer again. Retract the elements and then reselect the same band. The antenna should come back to very near the same setting. Do this 2 or 3 times on each band. Also, try going from the band being tested to any other band and back again and observe that the antenna comes back to the same resonant point. Now you know the antenna is tuning correctly from band to band and is consistent.

9. Once the antenna is installed on the tower, be sure to properly tune the antenna using an antenna analyzer as the manual outlines before applying any RF power. Every install height and environment is different and will affect the antenna's SWR and resonant point. You don't want to damage the antenna due to high power being applied with a large mismatch.
10. Enjoy the antenna!

73

Jim Streible—K4DLI

Jim passed away in early 2016, but his advice has enduring value.

WORD OF CAUTION

Be careful to avoid making contact with power lines or other potential hazards when constructing, moving and installing the antenna, as you could be seriously injured or even killed if a metal object comes in contact with high voltage.

STEPPIR DESIGN

Currently, most multi-band antennas use traps, log cells or interlaced elements as a means to cover several frequency bands. All of these methods have one thing in common—they significantly compromise performance. The SteppIR™ antenna system is our answer to the problem. Resonant antennas must be made a specific length to operate optimally on a given frequency.

So, instead of trying to “trick” the antenna into thinking it is a different length, or simply adding more elements that may destructively interact, why not just change the antenna length? Optimal performance is then possible on all frequencies with a lightweight, compact antenna. Also, since the SteppIR can control the element lengths, a long boom is not needed to achieve near optimum gain and front to back ratios on 20 - 10 meters.

Each antenna element consists of two spools of flat copper-beryllium tape conductor (.54” Wide x .008” Thick) mounted in the element housing unit. The copper-beryllium tape is perforated to allow a stepper motor to drive them simultaneously with sprockets. Stepper motors are well known for their ability to index very accurately, thus giving very precise control of each element length. In addition, the motors are brushless and provide extremely long service life.

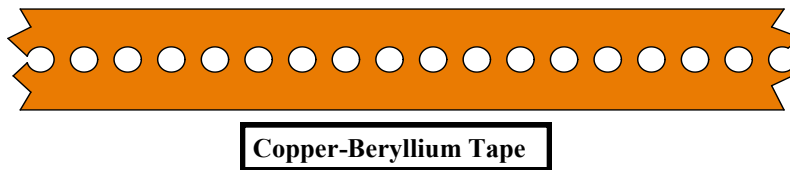

The copper-beryllium tape is driven out into a hollow fiberglass elements support tube (see below), forming an element of any desired length up to the limit of each specific antenna model (a vertical uses only one side). The fiberglass elements support tubes (poles) are telescoping, lightweight and very durable. When fully collapsed, each one measures approximately 59” in length. Depending on the model, there may be additional extensions added to increase the overall element length.

The ability to completely retract the copper-beryllium antenna elements, coupled with the collapsible fiberglass poles makes the entire system easy to disassemble and transport.

The antenna is connected to a microprocessor-based controller (via 22 gauge conductor cable) that offers numerous functions including dedicated buttons for each ham band, continuous frequency selection from 40m to 6m (depending on the model). There are also 17 ham and 6 non-ham band memories and you can select 180° direction reversal* or bi-directional* mode and it will adjust in just about 3 seconds (*Yagi only).

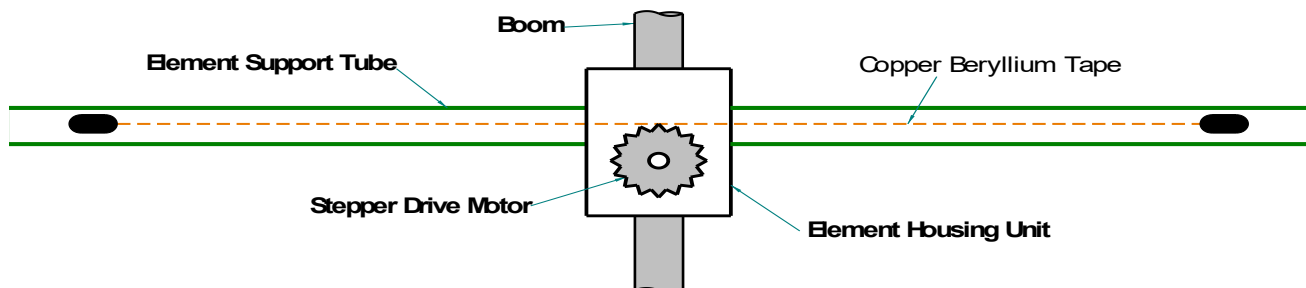

ABBREVIATIONS

EST	Element Support Tube
EHU	Element Housing Unit
QD	Quick Disconnect Boot (rubber)

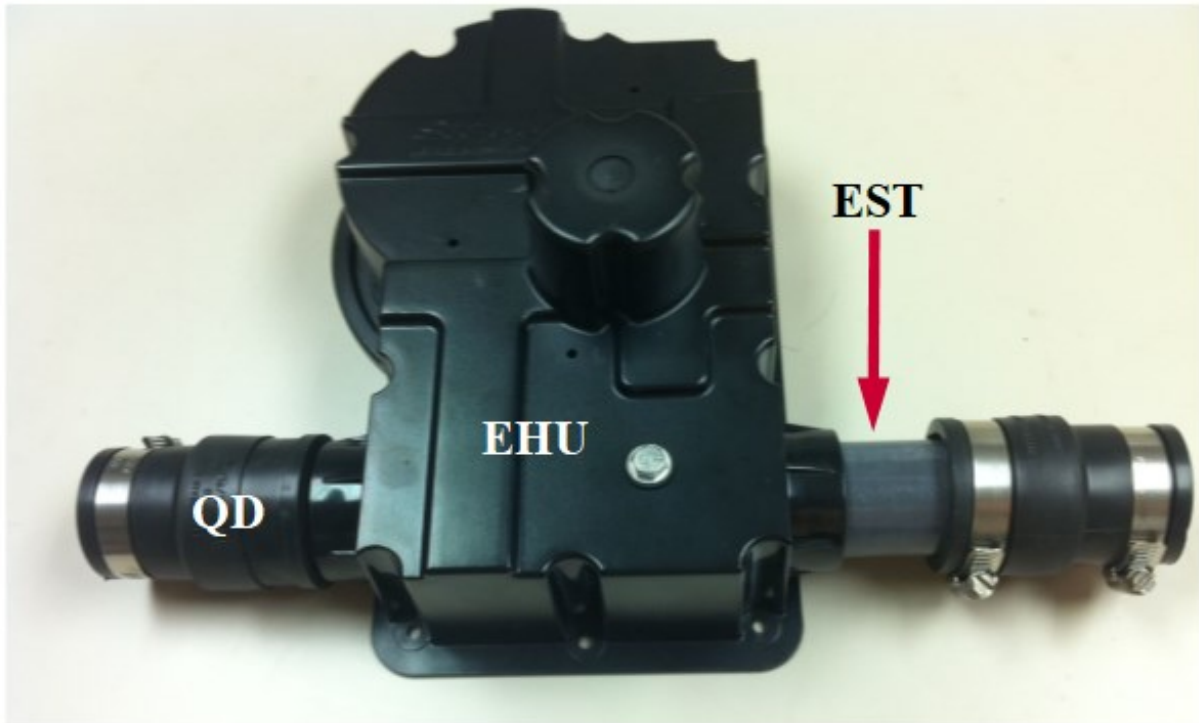

PARTS CHECKLIST

It is important that you do an inventory of the items that were shipped to you. We do our very best to ensure that you receive everything needed for construction of your antenna, but better to be safe than sorry—inventory your parts well in advance of your installation.

What Comes in the Antenna Box

✓	QTY	PART #	DESCRIPTION
	2	10-1013-02	Telescoping Pole, 18 foot 4 section
	4	10-1059-01	Polyolefin Heat Shrink 1-1/2"
	2	10-1059-21	Polyolefin Heat Shrink 1.1" x 6"
	2	60-1006-22	Quick Disconnect Boot, 1-1/2" to 1-1/4", Fernco
	2	70-1007-01	Foam plug assembly
	1	70-2030-21	DB Mounting Plate w/ Reinforcement Wings and Foam Mounting Guide
	1	70-3000-01	33 Volt supply with cord.
	1	70-3402-01	EHU, Dipole Assembly
	1	72-0015-22	Kit, 20m Dipole Hardware (New reinforced DB plate style)
	1	72-0054-21	Kit, EHU DB Plate Hardware
	1	70-6010-01	DB25 Field Splice
	1	10-1609-11	DB Mounting Plate Upper Reinforcement Bracket

72-2015-22

✓	QTY	PART #	DESCRIPTION
	8"	09-1022	Coax Seal, 12' x 1/2".
	4	10-1601-03	Saddle, 1-3/4" x 3/4"
	4	60-0046	Nut, 5/16" -18, Nylock
	4	60-0075	Bolt, 5/16" X 3-1/4", S/S
	2	60-0112	Set Screw, 10-32 x 1/4", Cup Point, S/S
	2	60-7019-11	Resin Clamp, 1.5"
	2	10-1612-01	Resin Clamp Spacer
	5	60-0041	Washer, 1/4", Flat (5c)
	5	60-0030	Nut, 1/4"-20, Nylock, S/S (5c)
	5	60-0100	Bolt, 1/4 -20 X 3-1/2", hex head, S/S
	9	60-0033	Washer, 5/16", Flat, S/S
	1	10-1609-21	EHU Shell Flange Reinforcement Bracket, Side
	1	10-1609-31	EHU Shell Flange Reinforcement Bracket, Top

PARTS CHECKLIST

72-0054-21

✓	QTY	PART #	DESCRIPTION
	11	60-0017	Screw, 10-32 x 3/4", Panhead
	11	60-0018	Washer, 10-32, Flat
	11	60-0019	Nut, 10-32, Nylock

STAINLESS STEEL FASTENER INFORMATION

From time to time, we get complaints from customers regarding galling of stainless steel fasteners.

Here is an excerpt from the Industrial Fastener Institute's Standards Book: *Thread galling seems to be the most prevalent with fasteners made of stainless steel, aluminum, titanium and other alloys which self-generate an oxide surface film for corrosion protection. During fastener tightening, as pressure builds between the contacting and sliding thread surfaces, protective oxides are broken, possibly wiped off and interface metal high points shear or lock together. This cumulative clogging-shearing-locking action causes increasing adhesion. In the extreme, galling leads to seizing - the actual freezing together of the threads. If tightening is continued, the fastener can be twisted off or its threads ripped out.*

During minor galling, the fastener can still be removed, but in severe cases of galling, a strong bond between the bolt and nut can prevent removal of fasteners. Here are two ways to minimize this effect: *Decreasing installation RPM speed will cause less friction and decrease heat generation. Lubrication used prior to assembly can dramatically reduce or eliminate galling. Recommended lubricants should contain higher amounts of molybdenum disulfide, such as graphite which is very commonly used as a solid lubricant or special anti-galling lubricants sold by chemical companies.*

We provide an anti-seize compound stick called "Thread Magic" with all of our antennas and **strongly encourage** you to use it to reduce the aggravation of galling. Nylock nuts are no exception—apply the anti-seize on fasteners that use Nylock nuts as well. The Thread Magic stick is fantastic and is good for all metal fastener use—and, you can get plenty of anti-seize on the fastener without getting it on your hands!

Turn-of-nut tightening of nuts to bolts is recommended where torque values are not named, with metal to metal connections. Turn the wrench/socket until it is flush with the material it will seat against and snug-tightened, and then turn approximately 2/3 of a rotation past that point. When in doubt use common sense to ensure the fastener is not too loose, or not too tight—both positions can cause issues. On all connections, check the tightness 30 minutes or more later to ensure no creeping has taken effect.

Contrary to popular belief, galling of stainless steel is not a symptom of a "cheap" fastener - it is prevalent in all types of stainless steel, aluminum, and titanium fasteners. You can be assured that the stainless steel fasteners we provide with our products are manufactured of very high quality.

Save yourself a lot of grief and always use a thread lubricant when working with stainless steel fasteners.



ANTENNA DIRECTION CONFIGURATION

Figure 1.01

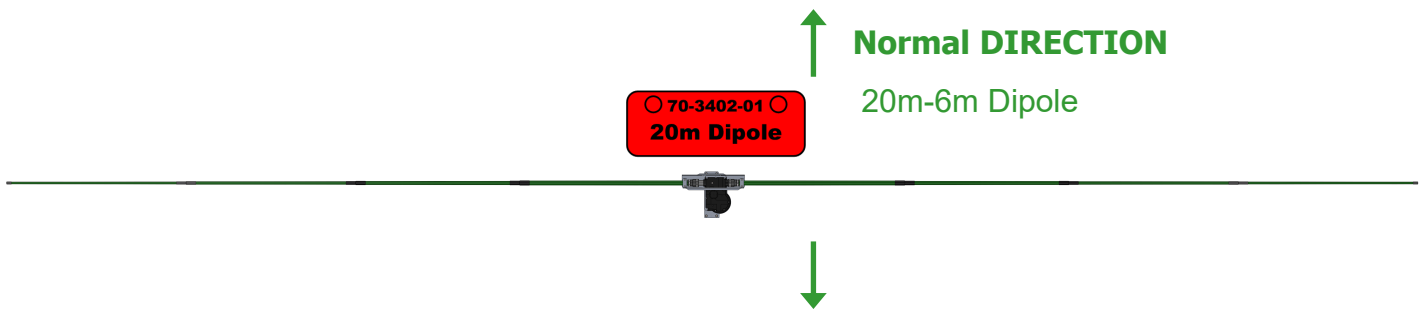

ANTENNA OVERVIEW AND DIAGRAM

Figure 1.02

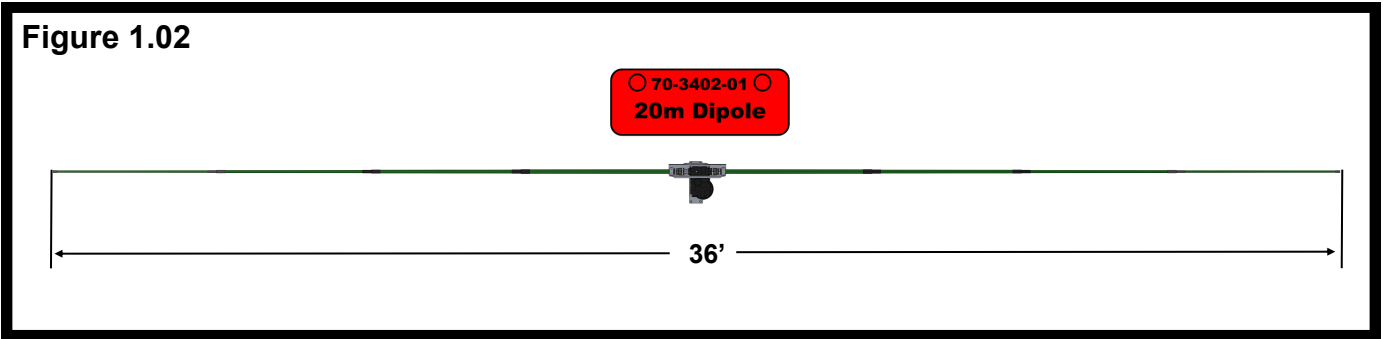

Figure 1.03



WIRING THE CONTROL CABLE TO THE DB25 SPLICE

Section 1.1: Preparing the Control Cable

SKIP TO PAGE 18 IF YOU HAVE A PREWIRED CABLE

1. Strip the jacket and aluminum shielding off of the control cable as shown in **Figure 1.11**, approximately 2.75" from end of control cable, being careful not to damage the individual wires.
2. Strip the plastic insulation off of each of the control cable wires, approximately 0.25" in length should be bare wire. Tinning of the copper wire ends with solder is NOT recommended by the connector manufacturer.

Section 1.2: Connecting control cable to the DB25 Field Splice

SKIP TO PAGE 18 IF YOU HAVE A PREWIRED CABLE

1. Apply the provided dielectric grease to the exposed copper portion of each wire. **Figure 1.22** shows what the connector protector will look like.

The terminals may be closed by default. If so, turn the terminal screw counterclockwise ~10 turns to open it before inserting the wires.

2. Consult **Figure 1.24** on the next page for the correct wiring sequence.
3. Connect each wire to the appropriate terminal and tighten using a flat head screwdriver. **Be sure you are clamping down on bare copper, not the insulation. Verify there is not excessive bare wire sticking out of the terminal or it may short to other pins/wires.**
4. Position the control cable between the cable clamp halves as shown in **Figure 1.23**. Electrical tape can be wrapped around the cables to increase the cable thickness if necessary.
5. Tighten the two pan head screws until the cable is snug, but do not over-tighten.
6. Thread the two thumb screws into the connector face as shown in **Figure 1.23**.
7. Plug the DB25 splice into the back of the controller, ensuring that it is fully seated, and twist the thumb-screws to secure it. For first time setups it is common for this to be only partially installed, resulting in fault codes on the controller.

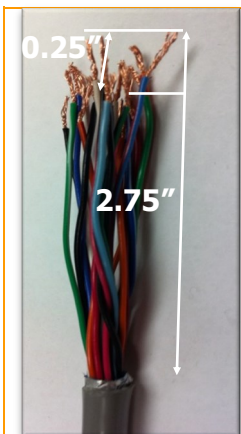

Figure 1.11



Figure 1.21



Figure 1.22



Figure 1.23

SKIP TO PAGE 18 IF YOU HAVE A PREWIRED CABLE

FIGURE 1.24

25 PIN DSUB FIELD
SPLICE TERMINAL
STRIPS (4)

4 WIRE CONTROL CABLE

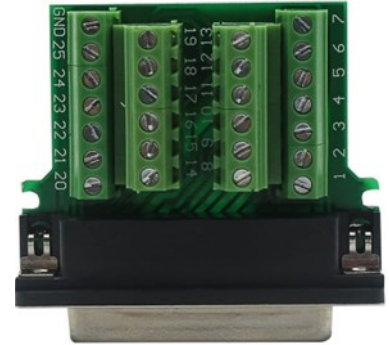
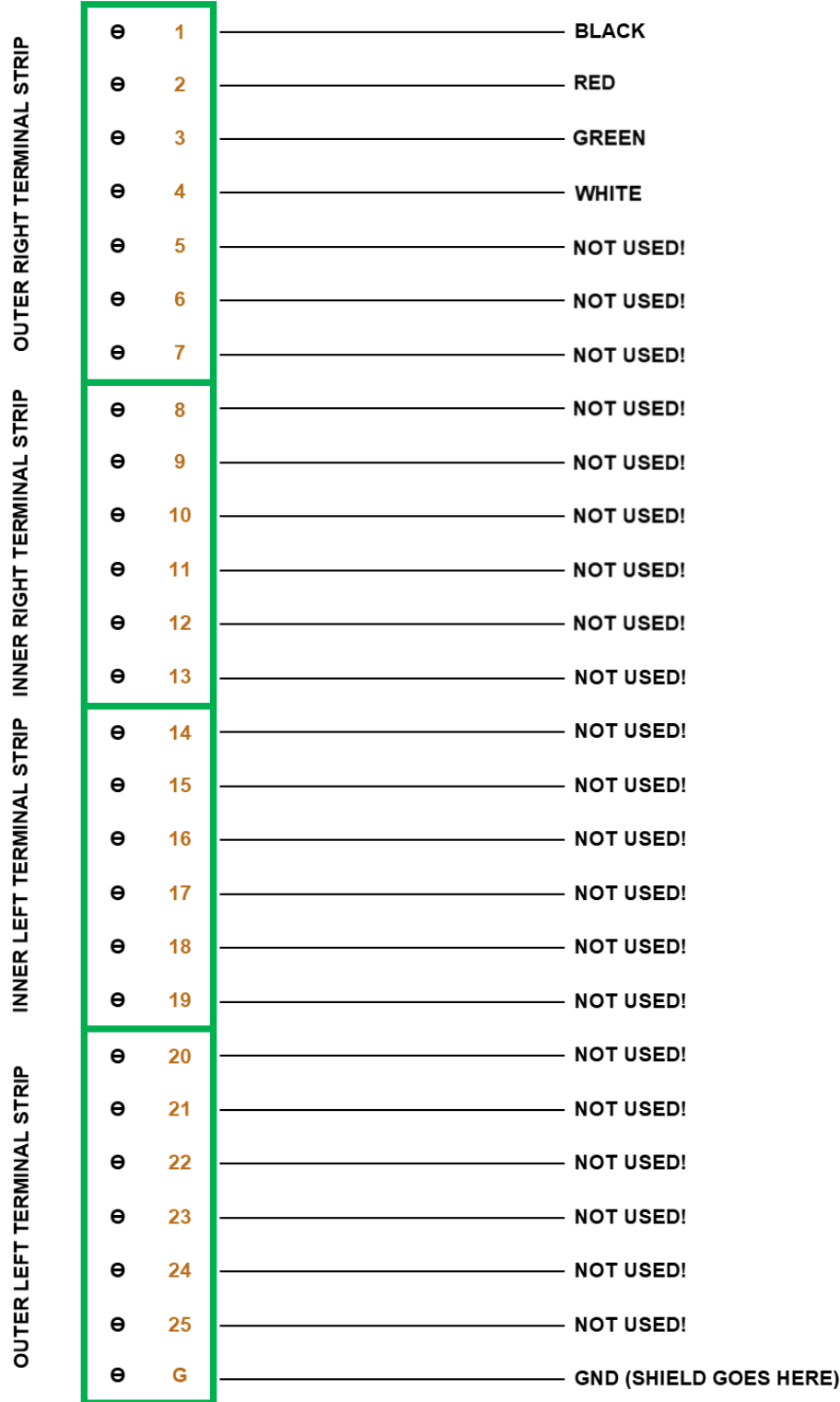

Figure 1.25

EHU OVERVIEW

SKIP TO PAGE 18 IF YOU HAVE A PREWIRED CABLE

Figure 1.30 gives an overview of the inside of a SteppIR EHU. Wiring of each EHU will be covered in detail on the following pages.

NEVER ATTEMPT ANY WIRING WHILE THE ELECTRONIC CONTROLLER IS CONNECTED TO THE CONTROL CABLE. Even if the power is turned off for the controller, damage can occur. This is the number one cause of antenna installation failure, so please be sure to heed the advice.

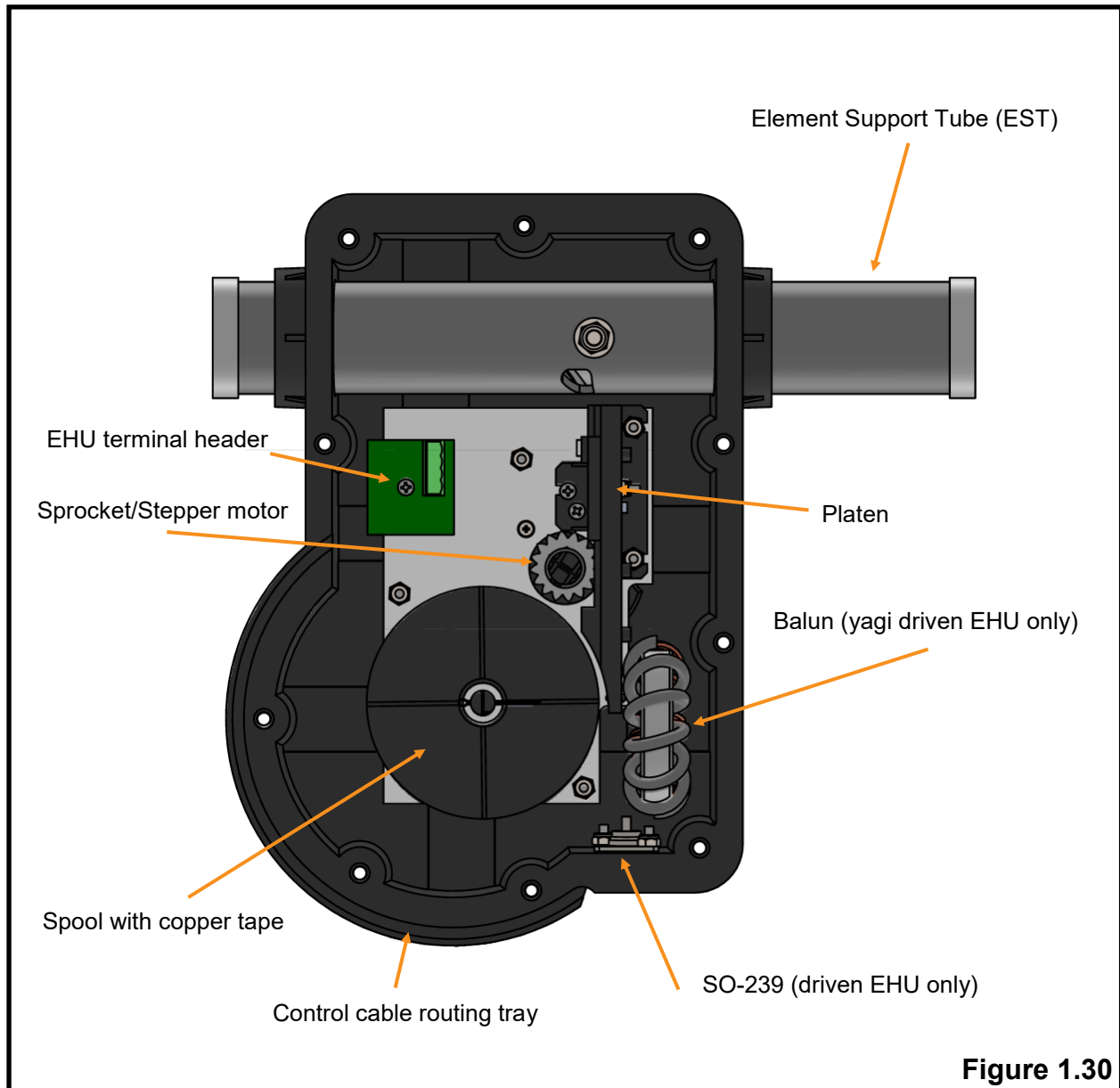

Figure 1.30

WIRING THE EHU

Section 1.3: Wiring the EHU

SKIP TO PAGE 18 IF YOU HAVE A PREWIRED CABLE

1. Trim approximately 1.5" of the outer jacket of the control cable.
2. Remove the outer foil shield, the support thread, and cut the shield wire off.
3. Attach electrical tape at the end of the trimmed control cable jacket so that there is no chance for a short.
4. Remove 0.25" of the insulation from each of the individual 22 AWG wires, leaving bare copper. **Tinning of the copper wire ends with solder is NOT recommended by the connector manufacturer.** **Figure 1.31** shows the control cable should look like when you are finished with the trimming.
5. Apply the provided dielectric grease to the exposed copper portion of each wire. **Figure 1.32** shows what the connector protector will look like.
6. The terminal header assembly consists of the terminal header and the terminal plug. The plug is shipped loosely attached to the header. Remove this plug when wiring and firmly plug back in when completed (**use dielectric grease on this terminal plug to prevent moisture ingress/corrosion**).
7. Follow the wire sequence in **Figure 1.34**. **Be careful to ensure that there are no bare wires protruding out from the terminal clamps, to avoid potential shorts. Also make sure you are clamping down on bare wire, and not the insulation of the wire.** The wiring sequence for the EHU is also imprinted on the PCB that the terminal header is mounted on (located inside the EHU), as shown in **Figure 1.33**. Pay no attention to the second row of imprinted text, these pins are for use in the manufacturing of the board itself and are of no use to you. **Figure 1.33** shows a red line crossing out the text in question. The orange circle shows the correct wiring sequence.

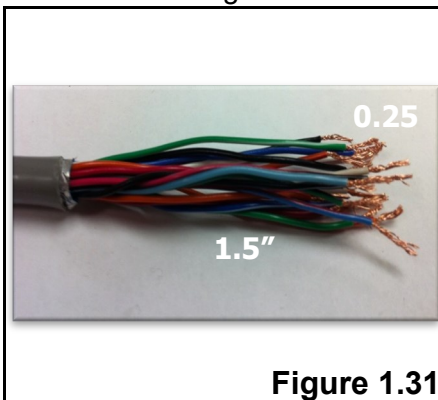

Figure 1.31



Figure 1.32

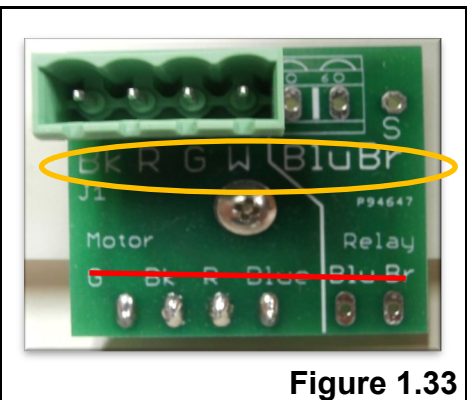

Figure 1.33

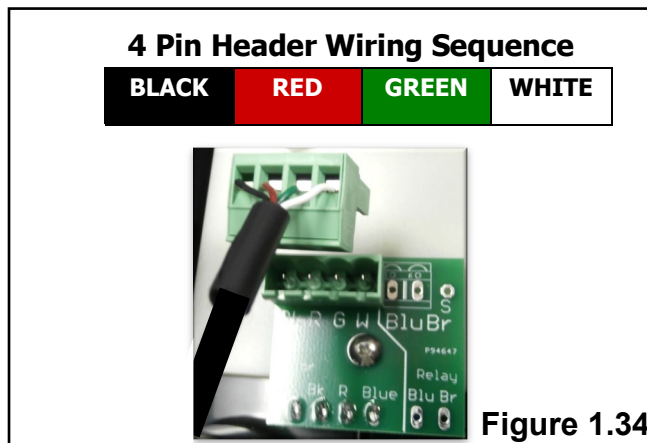

Figure 1.34

8. Check to ensure the terminal plug is firmly inserted into the terminal header.
9. Cut three 1-inch strips of coax seal for each EHU as shown in **Figure 3.45**, and place them at each end of the wire tray of the EHU, as well as one in the center as shown in **Figure 3.46**. This trough acts as a strain relief so that the cable will not be pulled out of the EHU. The remainder can be used to seal the driven element SO239 connector.
10. Lay the control cable wire inside the wire tray of the EHU then firmly press the cable into the trough as shown in **Figure 3.47**. It is a good idea to leave a small amount of slack between the plug and the point which the tray starts as shown in the circled region of **Figure 3.47**. **Be sure that the cable is fully seated in the trough, otherwise you may pinch and damage the cable during assembly.**
11. Wrap the coax seal around the control cable as shown in **Figure 3.48** and squish it flat. This will help keep water from entering into the EHU. Repeat this process to the remaining areas of the wire tray as shown in **Figure 3.49**.

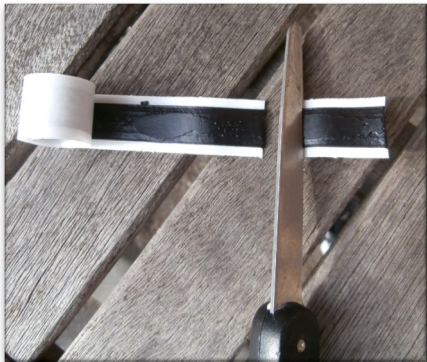

Figure 3.45

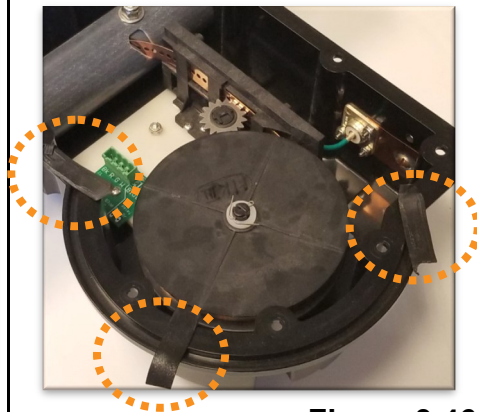

Figure 3.46

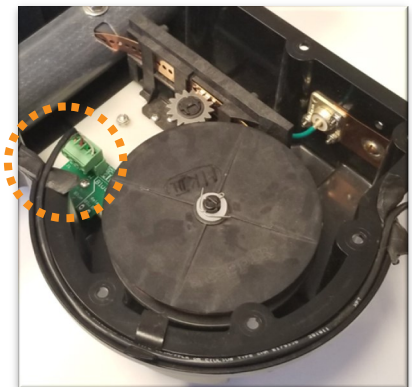

Figure 3.47

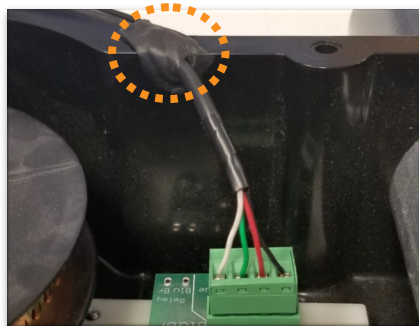

Figure 3.48



Figure 3.49

EHU WIRING TESTS

Section 2.1: Resistance Test (mandatory)

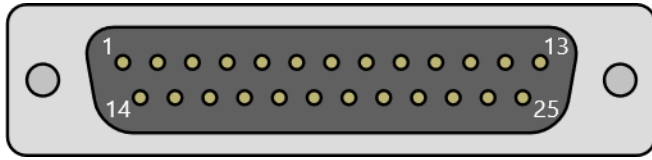

Figure 2.11

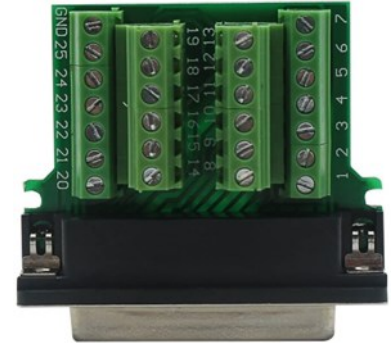

Figure 2.12

The control cable uses 4 wires per motor (one motor in each element housing unit (EHU)). Each motor has two wires for each of its two motor windings. This test assumes the antenna is connected to one end of the control cable and the measurements are taken at the 25-pin connector that mates to the controller (disconnected from controller). You need an ohmmeter capable of measuring 15 – 35 ohms with reasonable resolution or at least one that you can tell the difference between a dead short and 15 ohms.

Step 1: Be sure the 25-pin DSUB control cable connector is disconnected from the controller (your control cable should not be plugged into the controller until the Resistance/Open Circuit test is completed).

Step 2: Hold the DB25 connector so you are looking at the pins with them pointing at you or open the back shell of the DB25 field splice. If prodding the pins directly, orient the connector so the row with 13 pins is on top, now the upper left-hand pin is pin 1. See **Figure 2.11** for reference. If you decide to open the case of the connector, reference the pin number marking on the PCB (**Figure 2.12**).

Step 3: Measure the resistance between the pin pairs indicated. You only need to measure the resistance of wires that correspond to the elements on your antenna. The required pin pairs to measure are shown in the table below. You should read between about 15 ohms to 30 ohms depending on cable length between the pins listed below. Record your results in the “Results” column. (100’ is about 23 ohms).

Resistance Test Table			
Pin Pair	Antenna Element	Expected Resistance	Results (ohms)
1-2	Driven	~ 20 Ohms	
3-4		~ 20 Ohms	

Section 2.2: Open Circuit Test (mandatory)

Step 4: Next make sure there is an open circuit between the following pins. Record your results in the “Results” column. (Any reading < 100 K ohms is bad)

Open Circuit Test Table		
<i>Test Pins</i>	<i>Expected Resistance</i>	<i>Results (Ohms or Open Load (OL))</i>
Connector metal case to any pin	Open Load (OL)	
Pin 1 to any pin except 2	Open Load (OL)	
Pin 3 to any pin except 4	Open Load (OL)	

Conclusion

If your antenna passes this test it **does not** mean it is wired correctly. You could have an intermittent short or a short that requires higher current than what the ohmmeter can supply to reveal itself. You may have also swapped two elements or even wired the whole thing backwards (started at the wrong end of the terminal strip) and it will still measure correctly because each connector pair has a motor winding connected to it, but it is the wrong one. This test just takes you to the next step of trying to determine if the antenna is wired correctly and then finally determining if the elements are physically moving. This is an open loop system and the controller has no way of knowing if the elements are really moving when commanded to.

ATTACHING THE EHU TO THE DB MOUNTING PLATE

Section 3.1: Mounting the EHU to the DB Mounting Plate

- The EHU should already be wired before placing it on the DB mounting plate.
- Place the EHU gasket onto the mounting plate as shown in **Figure 3.11**. Remove all chads from the gasket holes if they are present. Align the gasket with the holes on the mounting plate.
- Place the EHU onto the mounting plate, then the EHU flange reinforcements across the top and side of the EHU.
- Attach the EHU to the DB mounting plate using the #10 x 3/4" machine screws, #10 flat washers #10 Nylock nuts. Note that there are no flat washers on the reinforcement flange. Be sure that the flat washer is between the machine screw head and the EHU housing.
- Tighten the Nylock nuts enough to compress the gasket material but do not over tighten or you can crack the plastic EHU housing. It is best to tighten the nuts twice, with the final tightening being the most aggressive. Let the EHU sit 15 minutes in between tightening.

Key	Qty	Part #	Description
A	1	10-1609-21	EHU Shell Flange Reinforcement Bracket, Side
B	1	10-1609-31	EHU Shell Flange Reinforcement Bracket, Top
C	1	10-1502-12	Gasket, for Black Housing EHU Updated spacing
D	10	60-0017	Screw, 10-32 x 3/4", Panhead, S/S
E	4	60-0018	Washer, 10-32, Flat, S/S (5c)
F	10	60-0019	Nut, 10-32, Nylock, S/S

This drawing has been pulled from another manual, the DB mounting plate should not be mounted to the mast at this point.



Figure 3.11

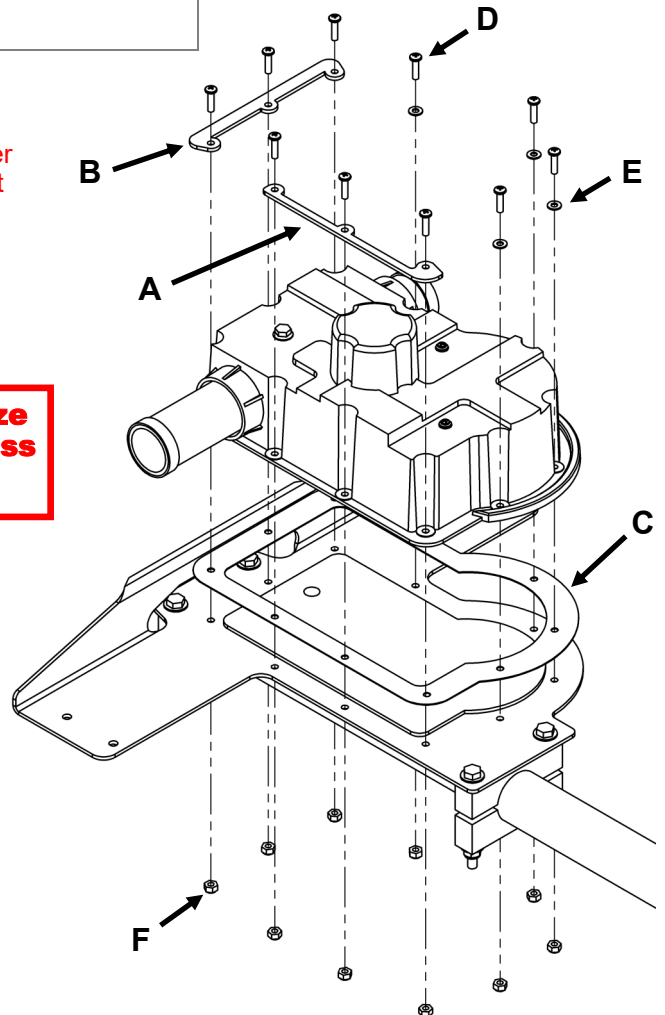

PREPARING THE TELESCOPING POLE

Section 4.1: Preparing the fiberglass pole

1. Extend the telescoping poles (PN 10-1013-02) to full length by firmly locking each section of the pole in place. A good methodology is to position each half of the joint so that they are several inches apart (while still within each other), and then pull quickly and firmly as shown in **Figure 4.11**. Do this for each pole. There are rubber plugs inside the base section of each telescoping pole. These make it easier for handling, but they **MUST BE REMOVED BEFORE ASSEMBLY. VERIFY THE FOAM INSERT IN THE PLUG HAS NOT MADE ITS WAY DOWN THE POLE AND THAT THERE IS NO OTHER FOREIGN DEBRIS INSIDE THE POLE.**

Figure 4.11

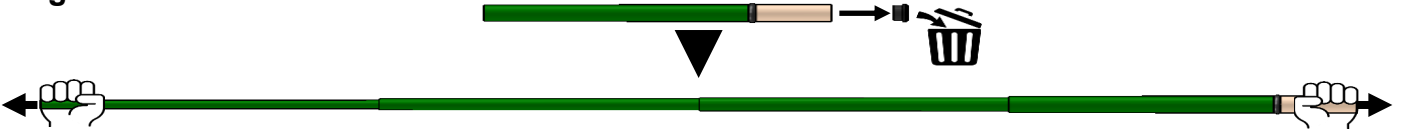

3. The telescoping pole uses 3 polyolefin heat shrink pieces, one covering each joint after it has been pulled tight. Once finished, the seal is secure and waterproof. This product requires a heat gun for activation of the adhesive.

4. When positioning the heat shrink, place it so that the joint of the telescoping pole is centered in the middle of the heat shrink.

5. Using a heat gun as shown in **Figure 4.14** (hair dryers will NOT work), apply heat evenly around the entire area of heat shrink. Note: there are 4 blue colored lines imprinted on the tubing. The joint is considered done being heated and waterproof when the lines change color to a yellowish green. Each line needs to change color to ensure even adhesion temperatures.

6. The heat shrink will want to slide as it is heated so wear gloves and reposition the heat shrink to keep it centered on the joint as needed. **Caution: The heat shrink will be HOT, wear insulated gloves!**



LOOK INSIDE OF THE TELESCOPING POLE TO VERIFY NOTHING IS BLOCKING IT. YOU SHOULD BE ABLE TO SEE LIGHT AT THE OTHER END IF THE POLE IS KEPT STRAIGHT. DEBRIS INSIDE THE TELESCOPING POLES CAN LEAD TO FAILURE OF THE EHU.



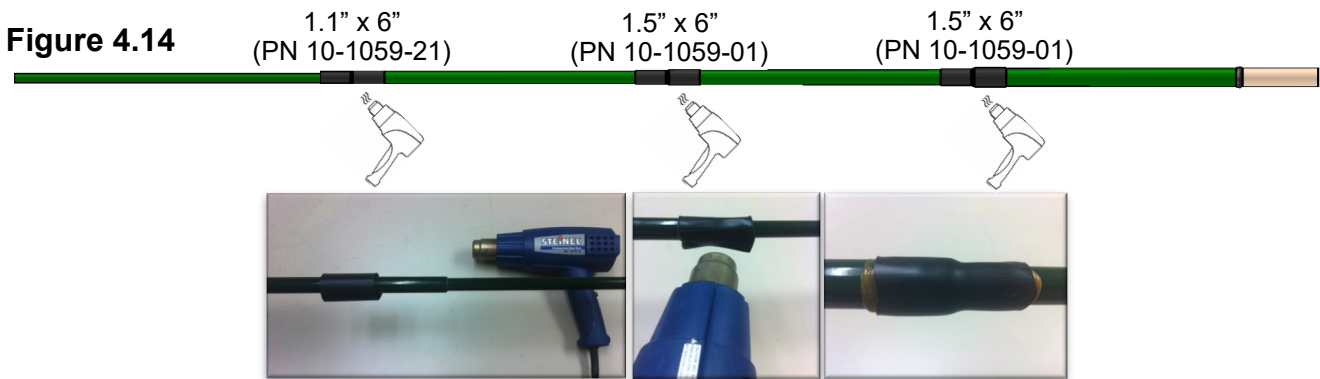

ATTACHING FOAM PLUG ASSEMBLY TO TELESCOPING POLE

Section 4.2: Adding Foam Plug Assembly to the Telescoping Poles

- Each 20m-6m telescoping pole tip requires a breathable foam plug to allow for venting of the EHU. The **foam plug assembly (PN 70-1007-01)** in **Figure 4.21** consists of a special UV resistant foam plug material, a SS screen, and a vinyl cap.
- The foam plug and SS screen is installed inside the vinyl cap at the factory.
- The fit of the vinyl cap on the pole tip is purposely very tight, so that the foam plug assembly will stay in place. Before attaching the foam plug assembly, spread a small amount of dish soap around the inside edge of the vinyl cap as shown in **Figure 4.22**. This helps the housing slide on easily, and the soap will eventually evaporate, leaving you with a firm interference fit.
- Insert the foam plug assembly onto the telescoping pole tip as shown in **Figure 4.23**. Be sure that the plastic housing bottoms out on the pole tip.
- Repeat for the other telescoping pole tip.

Figure 4.21



Figure 4.22



Figure 4.23



ATTACHING ELEMENTS TO THE EHU

Section 5.1: Securing the Telescoping Poles to the EHU

- Slide the rubber quick-disconnect boots (PN 60-1006-22) onto the telescoping fiberglass poles, smaller side first following **Figure 5.11** below.
- Insert the telescoping poles into the element support tube (EST) until the pole bottoms out in the EHU.
- Slide the quick disconnect boot down the pole until it butts up against the edge of the EST.
- Tighten both hose clamps on the quick disconnect boots firmly. Wait 20 minutes and tighten again—the flexible material will tend to cold flow initially. It is also a good idea to do a final tightening of all the quick disconnect boots and all fasteners as a last step before mounting the antenna onto the mast.

Key	QTY	Part Number	Description
A	2	60-1006-22	Quick Disconnect Boot, 1-1/2" to 1-1/4"
B	2	10-1013-02	Telescoping Pole, 18 foot 4 section

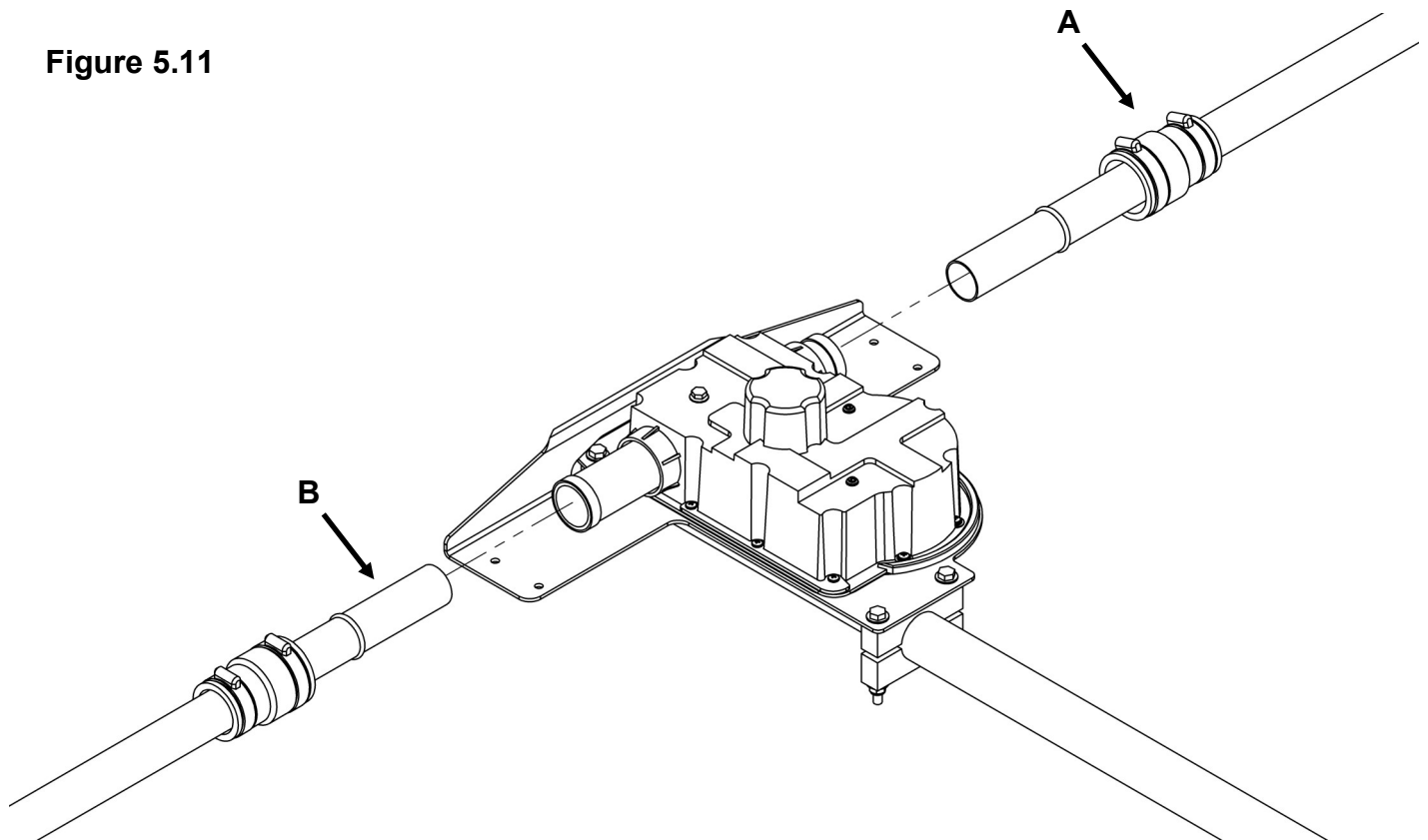

Figure 5.11

Section 5.2: Attaching the DB Mounting Plate Upper Reinforcement Bracket

- Install the DB mounting plate upper reinforcement bracket on all EHU's according to **Figure 5.21** below.
- First slide the resin clamp spacer and resin clamp half under the telescoping pole. This might be a tight fit so flex the telescoping pole up or the plate down slightly to allow the spacer and clamp to slide under the pole. Align the spacer and clamp with the holes in the plate.
- Place the other half of the resin clamp on top of the telescoping pole and align with the lower resin clamp.
- Place the DB mounting plate upper reinforcement bracket across the EHU and insert the 1/4"-bolts through the assembly. You may need to use a skinny screwdriver to get all the holes in the assembly to align properly. Place the 1/4" washer onto the bolt on the bottom side of the plate and thread on the 1/4" Nylock nuts. Tighten firmly.

Key	Qty	Part #	Description
A	2	60-7019-11	Resin Clamp, 1.5" (set)
B	2	10-1612-01	Resin Clamp Spacer
C	5	60-0041	Washer, 1/4", Flat
D	5	60-00-30	Nut, 1/4"-20, Nylock, S/S
E	5	60-0100	Bolt, 1/4 -20 X 3-1/2", hex head, S/S
F	1	10-1609-11	DB Mounting Plate Upper Reinforcement Bracket



Figure 5.21

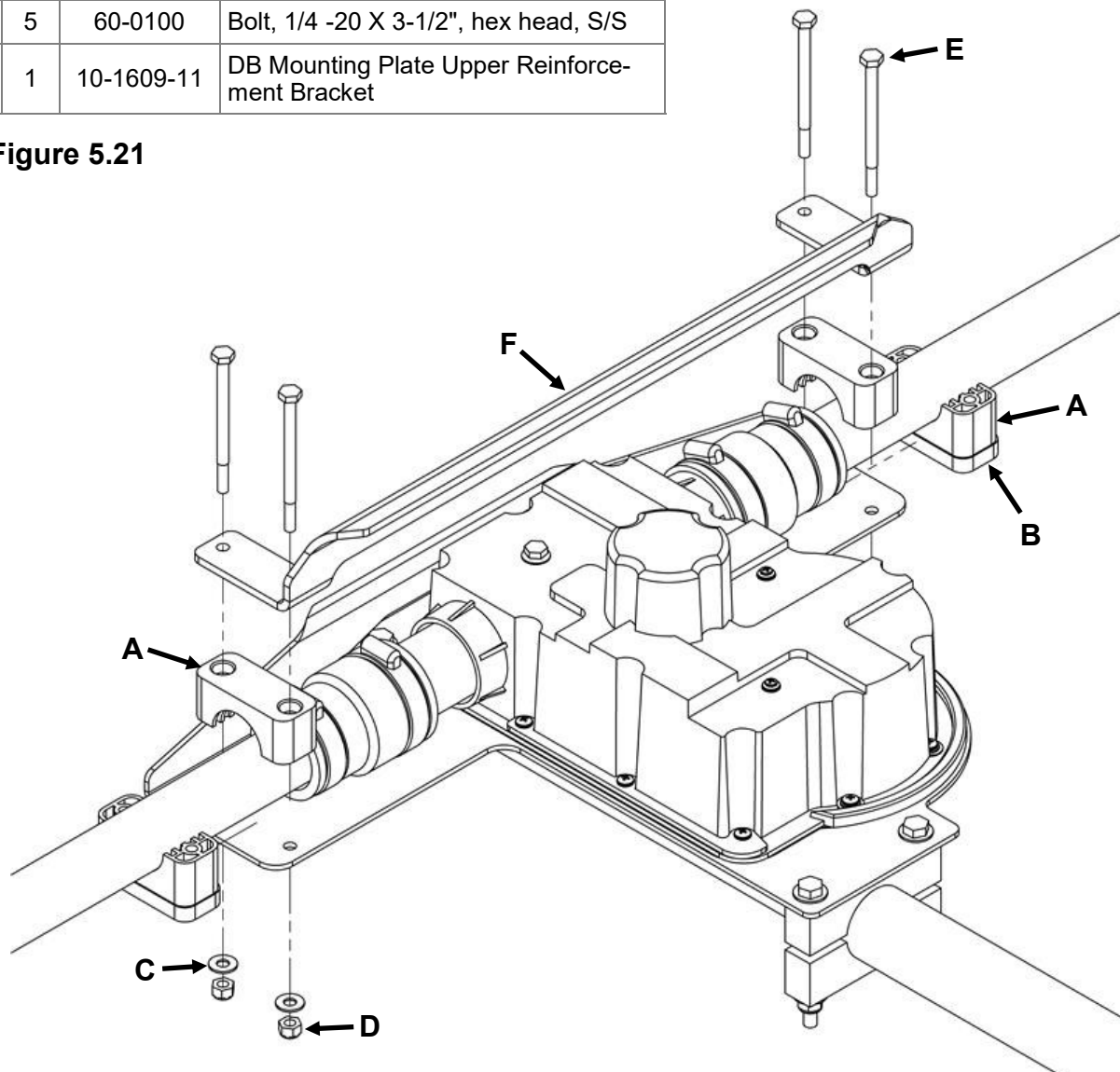

INSTALL MAST CLAMPS

Section 5.3: Installing Mast Clamps

- Install the clamps on the DB mounting plate following **Figure 5.31** below. The default clamps allow for mounting onto a 1-3/4" mast.
- Apply silicon to drain hole (E) to prevent water ingress.
- You are now ready to mount the antenna onto your tower!
- Once installed, tighten the set screws to prevent the antenna from twisting on the mast in high winds.

Key	QTY	Part Number	Description
A	4	60-0075	Bolt, 5/16" X 3-1/4", S/S
B	4	10-1601-03	Saddle, 1-3/4" x 3/4"
C	4	60-0046	Nut, 5/16" -18, Nylock
D	2	60-0112	Set Screw, 10-32 x 1/4", Cup Point, S/S
E			Drain Hole

This drawing shows the original DB mounting plate, the process is the same with the new reinforced DB mounting plate.

Figure 5.31

 **Use anti-seize on all stainless hardware!**

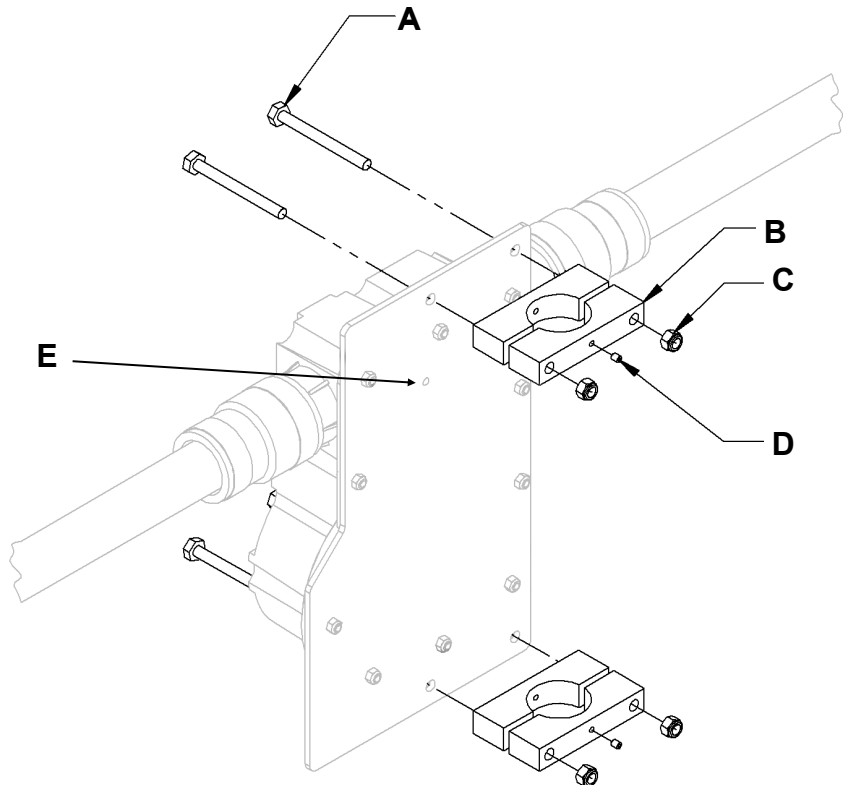

PTT LOCKOUT TUNING RELAY (INCLUDED)

To prevent application of unintended, excessive RF power while the SteppIR antenna is tuning, the SDA 100 and OptimizIR controller provides an isolated pair of contacts from a 3.5 mm stereo jack to interrupt the PTT relay signal to a linear amplifier. The cable is provided, but any standard 3.5 mm stereo plug to two RCA plug cable sold for audio applications works well in most cases. Some more modern amplifier relay control schemes are different and may not accommodate an RCA plug. Older amplifiers may use high voltage in their PTT circuit which may be a problem for some transceivers. Please read your amplifier and transceiver manuals carefully. The 3.5 mm plug tip and ring connect to isolated relay contacts inside the controller that interrupt the PTT circuit. The sleeve connection serves as a ground/shield. **Figure 6.01**

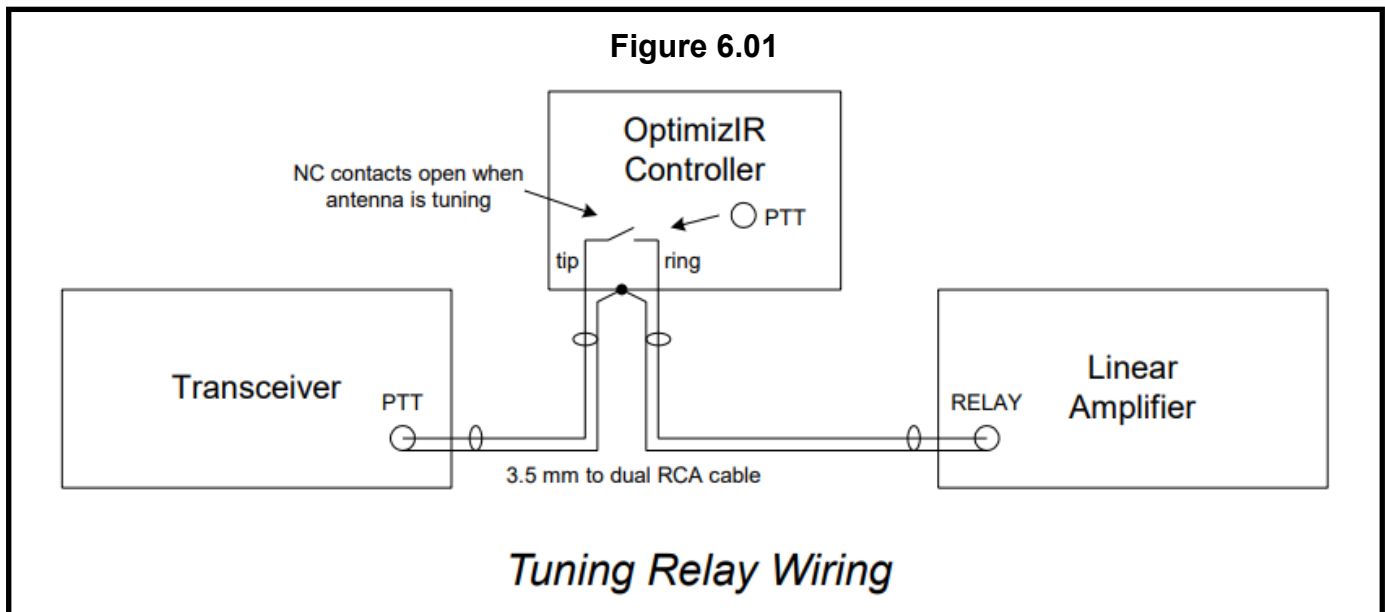

1:1 BALUN (OPTIONAL)

A balun is an electrical circuit used to help resolve the inherent problem of feeding an antenna with an electrically unbalanced (coax) feed line. It is intended to present an infinite impedance to any RF current that might otherwise flow on the outer conductor (shield) of the coax producing radiation from the line. This current, if high enough, can cause heat buildup and potential damage to the radio as well as a distorted radiation pattern and RF noise.

Why is it Optional ?:

There are too many variables outside of SteppIR's control that are installation specific and therefore should be up to the customer to decide on whether they would like to add a 1:1 balun to their system.

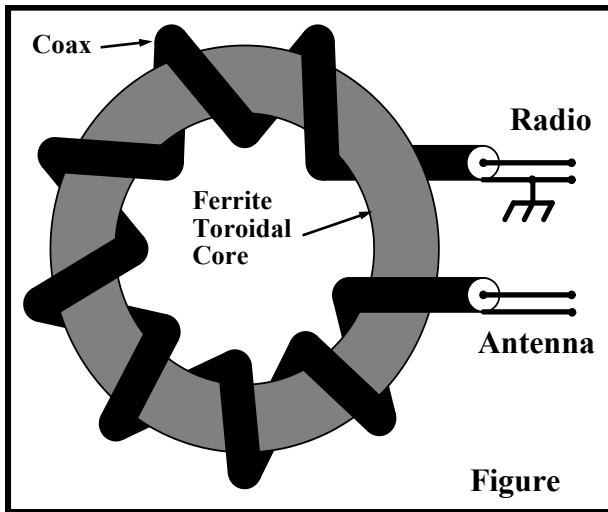

When Should You Use A Balun ?:

- When using coaxial cable instead of twin lead cable
- Unusual SWR readings on one band
- Excessive RF noise is observed

Balun Installation

The 1:1 balun should be placed as close as possible to the antenna and in between your feedline and the antenna as shown in **Figure 6.02**.

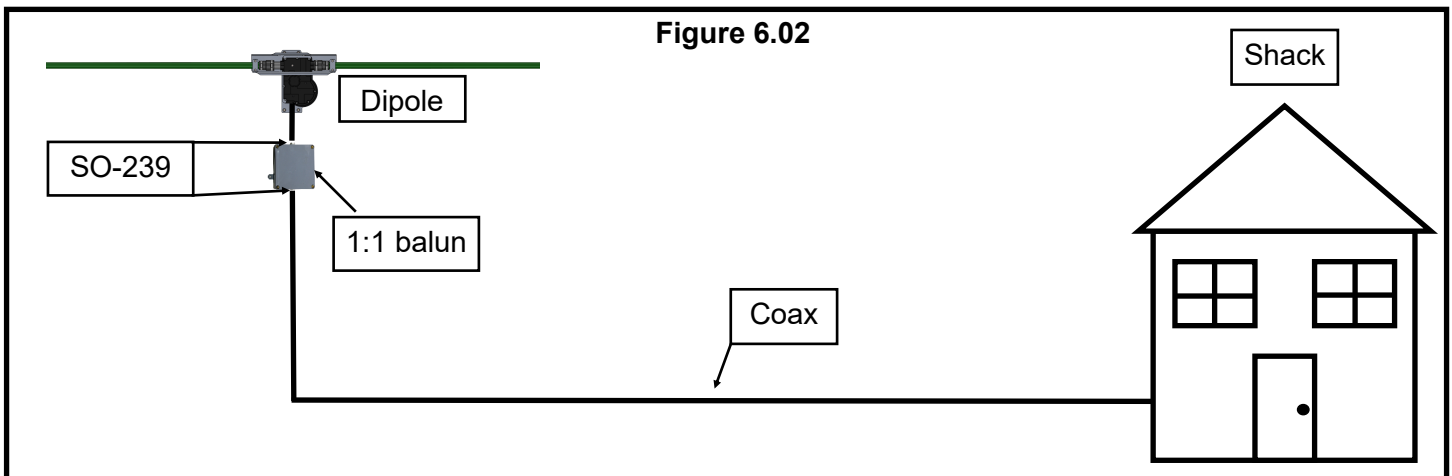

VOLTAGE/SURGE SUPPRESSOR (OPTIONAL)

- The Voltage/Surge Suppressor is can be installed at the base of the tower, or on a well grounded structure (ground rod or ground bus bar). It is recommended to mount this outside of the radio room.
- You will need to cut the control cable in order to install the Voltage/Surge Suppressor. **MAKE SURE THAT THE POWER IS TURNED OFF AND UNPLUGGED ON THE CONTROLLER AS WELL AS THE CONTROL CABLE UNPLUGGED.**
- The Voltage/Surge Suppressor **DOES NOT GO IN SERIES WITH THE CONTROL CABLE.** If you wire it this way, your control box **WILL NOT OPERATE.** The Surge Suppressor is a **SHUNT DEVICE.** To visualize the connection, think of a “T”. The control cable is the top of the “T” and the Surge Suppressor is the “leg” of the “T”.

Mounting the Voltage/Surge Suppressor:

1. Remove the two Galvanized U-Bolts from the mounting bracket.
2. Install the U-Bolts around the tower leg to suite your installation. If mounting to a ground post or ground bus bar then you may use the holes for the U-bolts as mounting holes to the post/bus bar.
3. Install the Voltage/Surge Suppressor, square washer plates and nuts.
4. Tighten the nuts. Over-tightening of the U-Bolts may result in bending of the aluminum bracket.
5. Visit your local hardware store or home center and pick up some Forked Crimp Style Lugs that will fit the #8 stud. You may either use crimp style lugs that need NO soldering or soldered lugs AND because they are fork style, you don't need to remove the nut to install them (Very handy when working on the tower!). It's a good idea to give the lug a tug to confirm it's crimped properly. **Soldered lugs are preferred if you have the capability to do so.**

The 8 Wire Surge Suppressor will require 16 Lugs. The 12 Wire Surge Suppressor will require 24 Lugs. The 16 Wire Surge Suppressor will require 32 Lugs.

6. If you match the colors of the leads on your control cables per stud, you should have no issues as shown in **Figure 6.03**. The Voltage/Surge Suppressor was checked at the factory for defects prior to shipment.
7. Make sure that you secure the control cable with tape or cable ties (aka Zip Ties) to the tower or ground rod as shown in **Figure 6.04**.
8. We recommend sealing up the connections by either using silicone tape or electrical tape to wrap the entire Voltage/Surge Suppressor and cable connections so that they do not corrode from moisture.

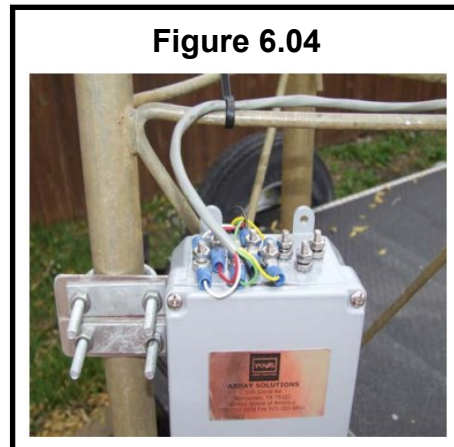
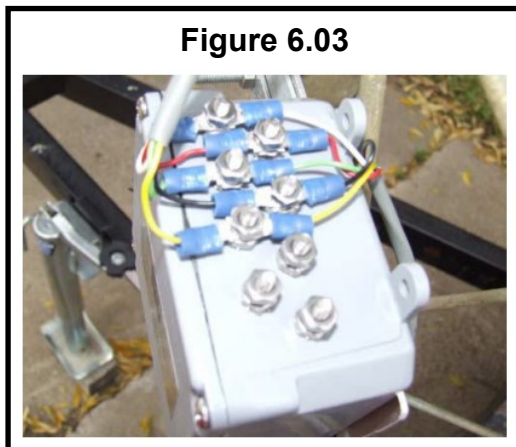

GROUNDING THE CONTROLLER (MANDATORY)

Make sure the controller is grounded! The ground lug locations are different for different controllers—the locations of the lugs for each type of controller are shown in the photos below.

To ground the controller, remove the yellow cap on the lug and take off the first nut and star washer. Attach a ring lug to the grounding wire and secure it to the ground lug by placing the ring lug, then star washer, then screwing the nut back on. Tighten with a wrench or socket. The other end of the wire should connect to any suitable ground point, typically a ground bus bar used for station ground.

Figure 6.05: Lug location for SDA100, OptimizIR, and OptimizIR 2.0 (early models)



Figure 6.06: Lug location for OptimizIR 2.0 (stainless steel chassis)



HOW TO TUNE YOUR DIPOLE (MANDATORY)

The impedance of a half wave horizontal dipole depends on its height above ground. In the frequency range of 14 to 28 MHz, the typical height of an amateur radio antenna is between 1/2 and 1 wavelength above ground. At these heights the impedance of a horizontal 1/2 wave dipole is in the vicinity of 70 to 80 ohms. When the antenna is mounted at heights greater than 1/2 wavelength, it should exhibit an SWR of less than 1.5 to one. At lower heights, the SWR may be higher.

A dipole antenna's resonant frequency is determined by the length of its element, height above ground, as well as a variety of other factors. Since every installation is different, the factory default lengths in the controller for each band/frequency are almost guaranteed to be need adjustment for your particular installation. Because of this, **it is mandatory to tune the length of the antenna on all frequencies of operation before application of high power.**

This is done by pressing "Setup" and selecting the "Create/Modify" menu. In this menu, the operator can adjust the length of the driven element (DVR/DE) until the SWR is at least below 1.4-1.3. An antenna analyzer (Vector Network Analyzer) is extremely helpful for this task as it allows the user to plot SWR over a frequency range, at which you can match the SWR dip in the antenna with the frequency which you are tuning in the create/modify menu. **If you are unable to make a good match by adjusting the length of the driven element, you most likely have an issue with your connections.**

SteppIR antenna tunes are broken up into "segments" which we use to create an ideal antenna at a specific frequency. Each segment consists of a frequency, element lengths, and some miscellaneous display settings like gain, F/R, and beam width. To get the element lengths at frequencies in between segments, the controller utilizes an algorithm to calculate them with the given segment information. The controller can only "store" lengths at the start of each segment, and it calculates the lengths in between. What this means for the end user is that the antenna can only be tuned once in between each segment.

Important notes:

- Start tuning by first calibrating the antenna.
- You will want to tune starting at the highest frequency and work your way down to lower frequencies.
- Send the antenna to the recommended tune frequency, scan a large span (the SWR dip may be outside of the ham band) with your antenna analyzer and find the minimum SWR. Lengthen/shorten the dipole element until you have a low SWR at the controller frequency.
- In order to save a setting in the Create/Modify menu, you can simply exit from the screen by pressing "Setup" again, and when the controller prompts you whether you want to save your changes make sure you select "Yes" to save your changes.

On the next pages are lists of the segments, segment frequencies, and recommended tune frequencies for the dipole on the OptimizIR and SDA100 controllers.

OptimizIR / OptimizIR 2.0 recommended tuning frequencies

Segment #	Start	End	Tune Frequency	Ham Band
11	51.00	65.00	52.5	6m (50-54)
10	49.50	51.00	50.5	
9	41.00	49.50	45.25	-
8	34.50	41.00	37.75	-
7	29.00	34.50	29.35	10m (28.0-29.7)
6	27.50	29.00	28.5	
5	24.60	27.50	24.94	12m (24.89-24.99)
4	20.80	24.60	21.225	15m (21.0-21.45)
3	17.85	20.80	18.118	17m (18.068-18.168)
2	15.80	17.85	16.825	-
1	13.85	15.80	14.175	20m (14.0-14.35)

Please refer to the create/modify section of the controller manual and our Tech Support Video section on our website for more information on tuning.

OptimizIR Manual:

https://consumer.steppir.com/wp-content/uploads/2018/05/SDA-2000-OptimizIR-Manual-Version-1_4-April-17-2018.pdf

Tech Support Videos:

<https://consumer.steppir.com/support/tech-support-videos/>

SDA100 recommended tuning frequencies

Segment #	Start	End	Tune Frequency	Ham Band
11	51.00	65.525	52.5	6m (50-54)
10	49.50	51.00	50.5	
9	41.00	49.50	45.25	-
8	34.50	41.00	37.75	-
7	29.00	34.50	29.35	10m (28.0-29.7)
6	27.50	29.00	28.5	
5	24.60	27.50	24.94	12m (24.89-24.99)
4	20.80	24.60	21.225	15m (21.0-21.45)
3	17.85	20.80	18.118	17m (18.068-18.168)
2	15.80	17.85	16.825	-
1	13.85	15.80	14.175	20m (14.0-14.35)

Please refer to the create/modify section of the controller manual and our Tech Support Video section on our website for more information on tuning.

SDA100 Manuals:

Mustang Firmware:

<https://consumer.steppir.com/wp-content/uploads/2020/10/SDA100-Operators-Guide-MUSTANG.pdf>

Pinto Firmware:

<https://consumer.steppir.com/wp-content/uploads/2011/10/operations-manual-SDA-100-rev-2-dec-12.pdf>

Tech Support Videos:

<https://consumer.steppir.com/support/tech-support-videos/>

STEEPIR OPTIONS

- “Y” Cable



- Transceiver Interface (Rig Specific)



- Voltage suppressor (8 conductor)

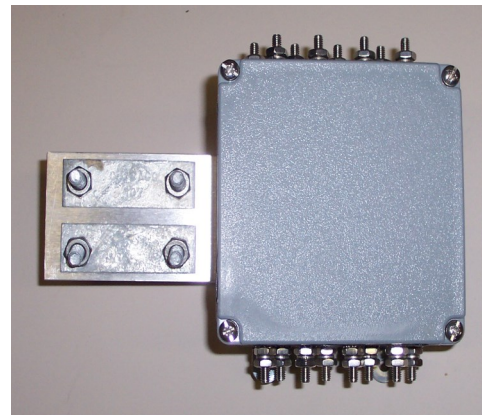

- 1:1 Balun



- Element Expansion Kit

Dipole to 2 Element

STEPPIR COMMUNICATION SYSTEMS 5 YEAR LIMITED PRODUCT WARRANTY

(as of May 22, 2023; Prior to that date warranty is 2 years)

Our products have a limited warranty against manufacturers defects in materials or construction for five (5) years from date of shipment. Do not modify this product or change physical construction without the written consent of Fluidmotion Inc, dba SteppIR Communication Systems.

This limited warranty is automatically void if the following occurs: improper installation, unauthorized modification and physical abuse, customer misuse or damage from weather events or natural disasters that are outside of the stated survivability of the product. For wind damage, proof of winds beyond 100 mph must be presented. Lightning or near-lightning events are not covered under this warranty. Driver chip module replacement is not covered under this warranty. This warranty is not transferrable.

SteppIR Communication System's responsibility is strictly limited to repair or replacement of defective components, at SteppIR's discretion. SteppIR will not be held responsible for any installation or removal costs, costs of any ancillary equipment damage or any other costs incurred as a result of the failure of our products.

In the event of a product failure, a return authorization is required for warranty repairs. This can be obtained at www.steppir.com. Shipping instructions will be issued to the buyer for defective components, and shipping charges to the factory will be paid for by the buyer. SteppIR will pay for standard shipping back to the buyer. The manufacturer assumes no further liability beyond repair or replacement of the product.

Modification of this product is not authorized and may cause product failure, injury or death.

